

KUHL[®]
— MESSER —



INDUSTRIAL RAZOR BLADES

Kühl Messer



www.kuhlmesser.de

INDUSTRIAL RAZOR BLADES



www.kuhlmesser.de

Special knives are produced according to the demands of our customers.

Please be informed that besides our products mentioned here alternative materials, coatings and measurements are available from our company stock.

Slitter Razor Blades



3 Hole Blades

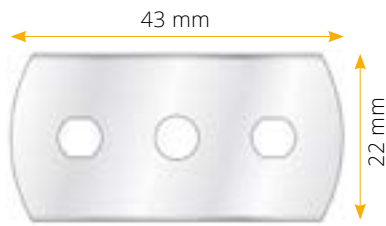

43 x 22 x Kalınlık / Thickness



43 x 22 x Kalınlık / Thickness

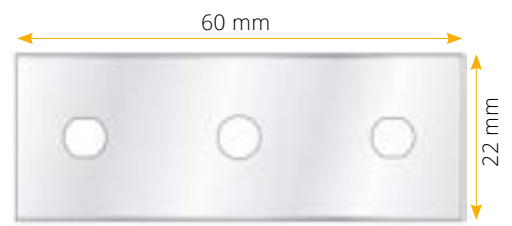

60 x 22 x Kalınlık / Thickness

Kalınlık / Thickness

0.10 - 0.13 - 0.15 - 0.20 mm
0.10 TİN - 0.15 TİN - 0.20 TİN
Tungsten Carbide
Seramik / Full Ceramic

Kalınlık / Thickness

0.10 - 0.15 - 0.20 - 0.30 mm
0.10 TİN - 0.15 TİN - 0.20 - 0.30 TİN
mm
Tungsten / Carbide
Seramik / Full Ceramic

Kalınlık / Thickness

0.15 - 0.20 - 0.30 mm
0.15 TİN - 0.20 - 0.30 TİN mm
Tungsten / Carbide
Seramik / Full Ceramic

Slotted Razor Blades

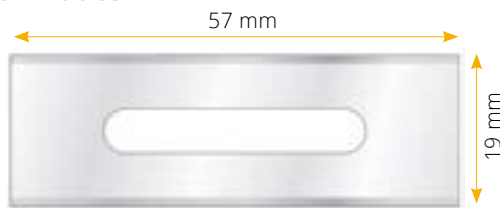

57 x 19 x 0.38 mm

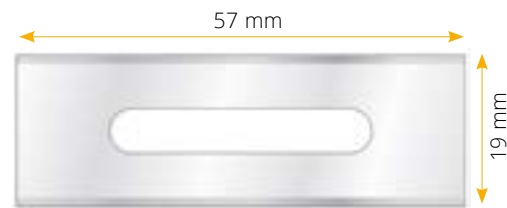

57 x 19 x 0.38 mm

Material

Carbon Steel
TIN Coated
Steel + Full Ceramic Coating
Carbide
Full Ceramic

Thickness

0.38 mm
0.38 mm
0.38 mm
0.38 mm
0.38 mm

Single Edge Razor Blades

With Spine

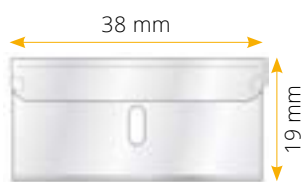

38x19x0.20 - 0.30 mm

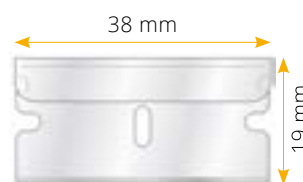

38x19 x 0.20 - 0.30 mm

Without Spine

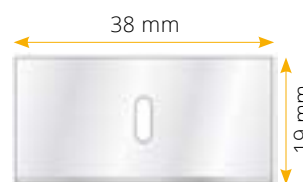

38x19 x 0.20 - 0.30 mm

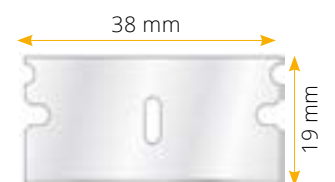

38x19 x 0.20 - 0.30 mm

Injector Razor Blades

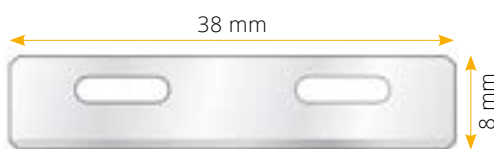

38 x 8 x 0.25 mm

Material

Stainless Steel
Carbon Steel
TIN Coated
Steel + Ceramic + Coating
Tungsten / Carbide (Without Slot)
Full Ceramic (Without Slot)

Thickness

0.25 mm
0.25 mm
0.25 mm
0.25 mm
0.25 mm
0.25 mm

Hook Blades



49 x 19 x 0.6 mm



49 x 19 x 0.6 mm



52x19x0.6 mm



52 x 19 x 0.6 mm



49 x 19 x 0.6 mm



49 x 19 x 0.6 mm

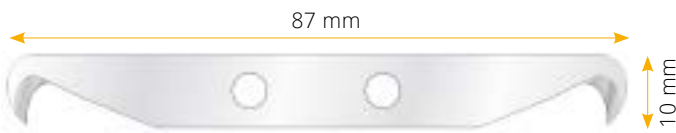

87 x 10 x 0.7 mm

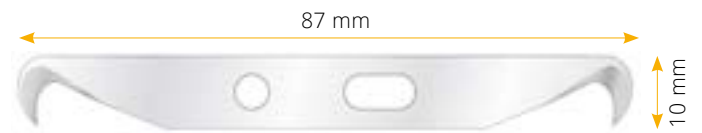

87 x 10 x 0.7 mm



59 x 19 x 0.6 mm



80 x 13 x 0.7 mm

Slim Knife Blades



55.5 x 10.3 x 0.53 mm

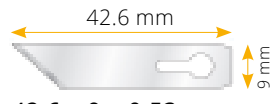

42.6 x 9 x 0.53 mm

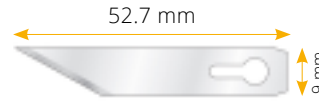

52.7 x 9 x 0.60 mm



50 x 9 x 0.60 mm

Lamel Blades

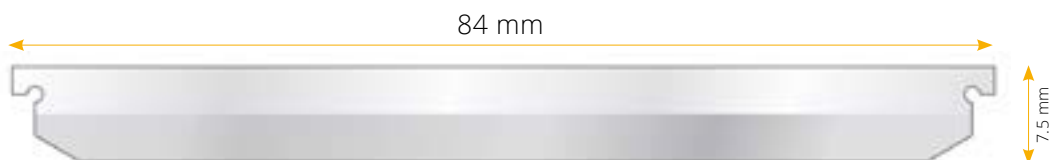

84 x 7.5 x 1 mm

Fiber And Fiberglass Chopper Blades

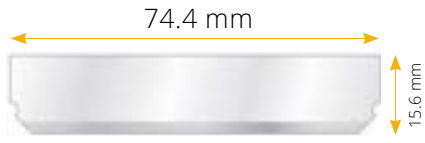

74.4 x 15.6 x 0.84 mm

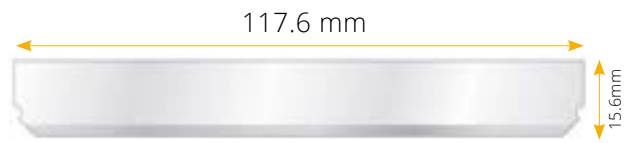

117.6 x 15.6 x 0.84 mm

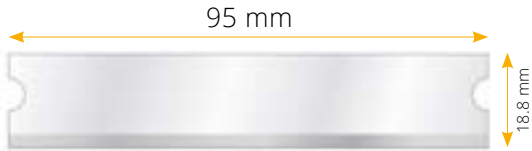

95 x 18.8 x 0.91 mm

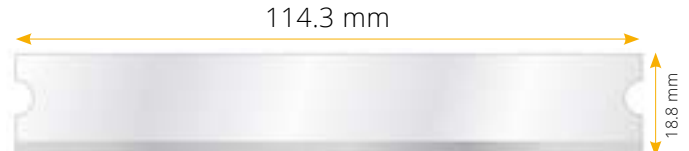

114.3 x 18.8 x 0.91 mm



Length x 8.00 x 0.30 mm

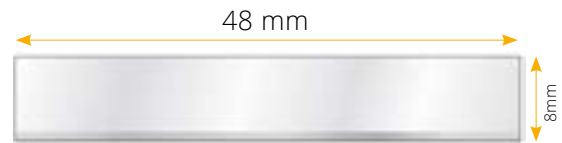

48 x 8 x 0.90 mm

Hobby Knife Blades



55.5 x 8.4 x 0.53 mm



40 x 9 x 0.53 mm



37 x 10 x 0.53 mm

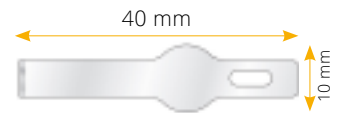

40 x 10 x 0.53 mm



45 x 13 x 0.63 mm
45 x 16 x 0.63 mm
45 x 20 x 0.63 mm



39 x 11.7 x 0.63 mm



45 x 10 x 0.60 mm

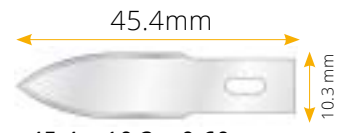

45.4 x 10.3 x 0.60 mm

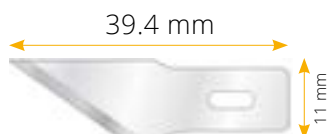

39.4 x 11 x 0.63 mm



47 x 11 x 0.63 mm



45 x 11 x 0.63 mm

Trapezoid Blades

Heavy Duty Blades (0.64 mm)

Short Type

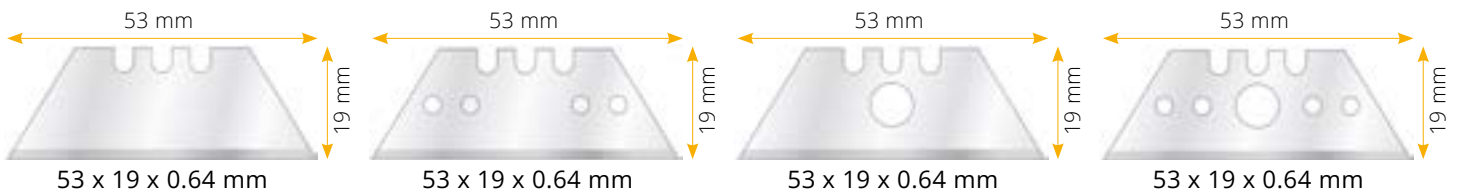

Standard Type

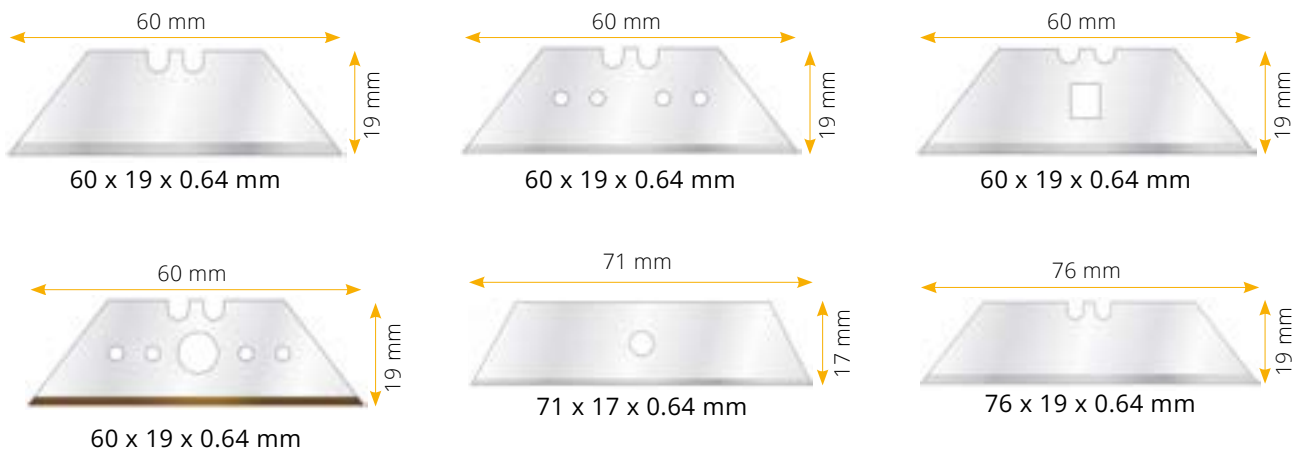

Wall Scraper Blades

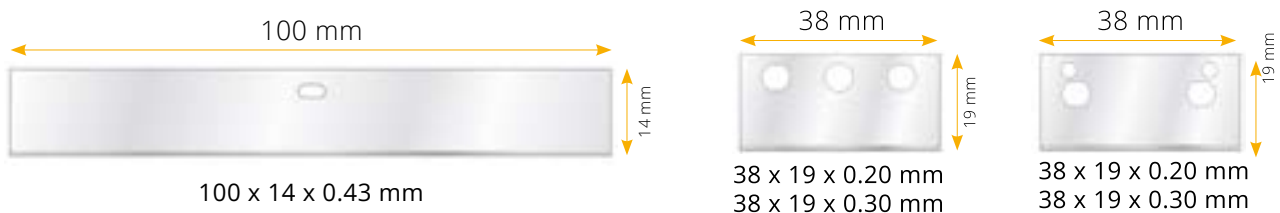

Carbide Warex Razor Blades

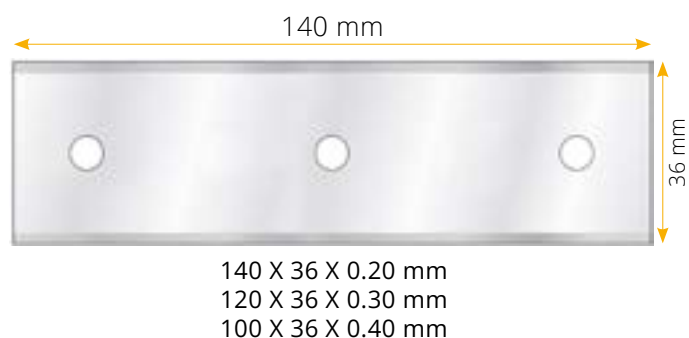

Snap Off Blades

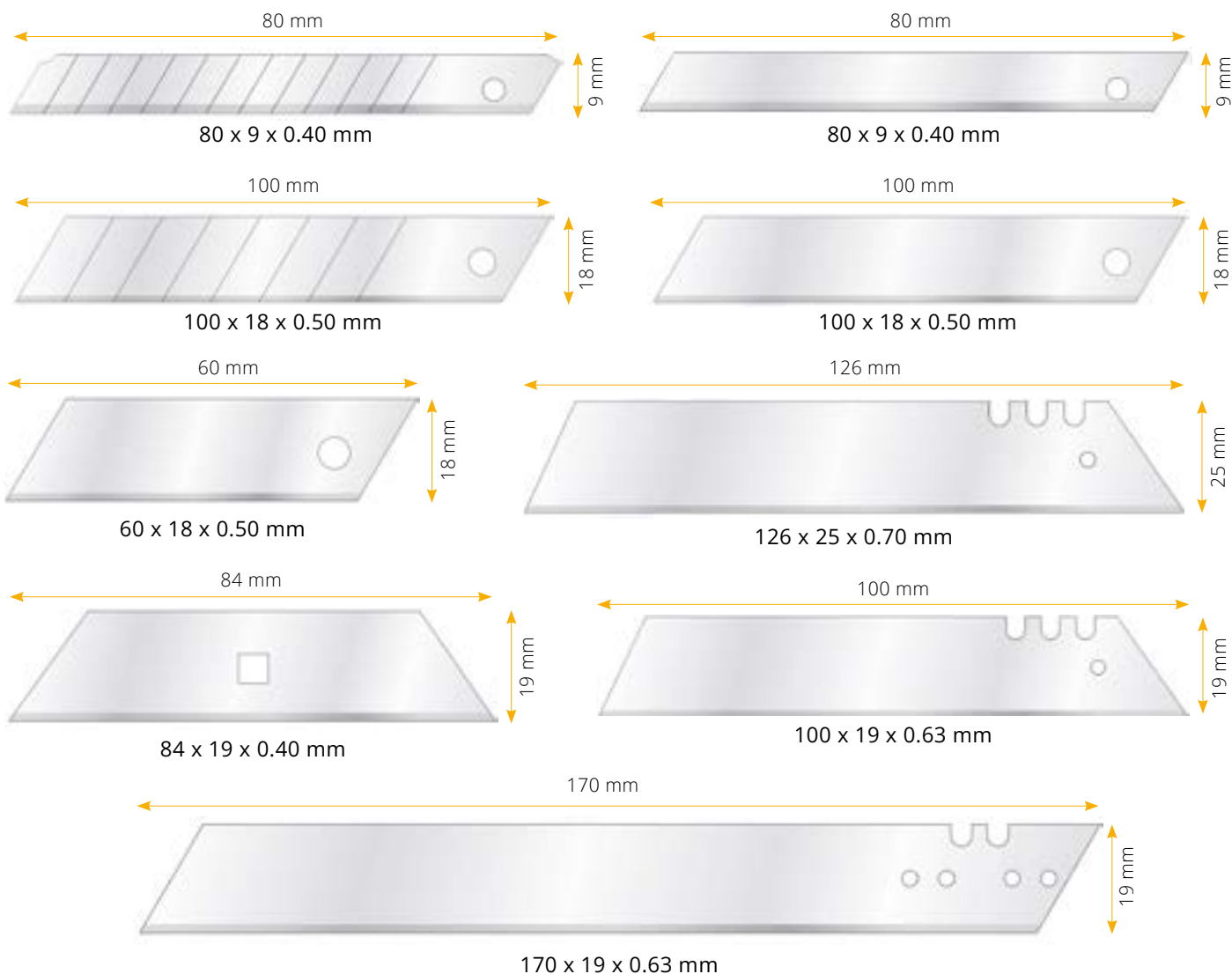

Pentagon Blades

Circular Blades

Triangle Blades

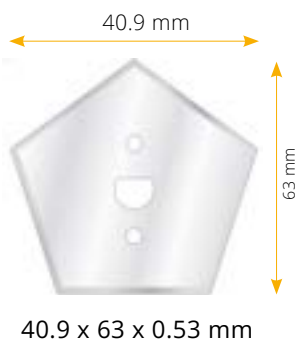

Thickness

66 x 63 x 0.53 mm
Tungsten / Carbide
Full Ceramic

Thickness

28 x 8 x 0.30 mm
45 x 8 x 0.30 mm
60 x 8 x 0.30 mm
Tungsten / Carbide
Full Ceramic

Thickness

44 x 22 x 0.20 mm
Tungsten / Carbide
Full Ceramic



KUHL[®]
— MESSER —

INDUSTRIAL RAZOR BLADES

Kühl Messer



www.kuhlmesser.de